

PART NAME

FUTURA CABINET

PART No.

MD-1960 THRU MD-1962

**MATERIAL:**

BODY, BOTTOM & REAR PANEL \_\_\_\_ 20 GA. STEEL  
 FRONT PANEL \_\_\_\_\_ 18 GA. STEEL

**FINISH:**

BODY, BOTTOM & REAR PANEL \_\_\_\_ ROYAL BLUE TEXTURED  
 FRONT PANEL \_\_\_\_\_ WHITE TEXTURED  
 RUBBER FEET \_\_\_\_\_ GRAY

BOTTOM AND REAR PANEL ASSEMBLED WITH #6 x 1/4 LG. SELF TAPPING SCREWS.

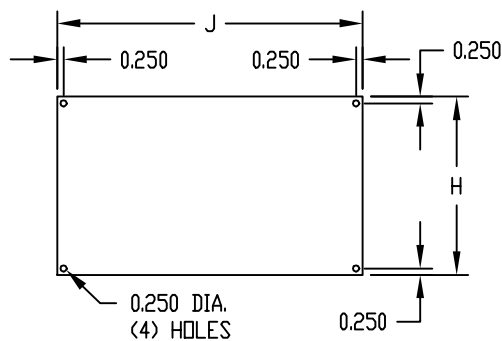
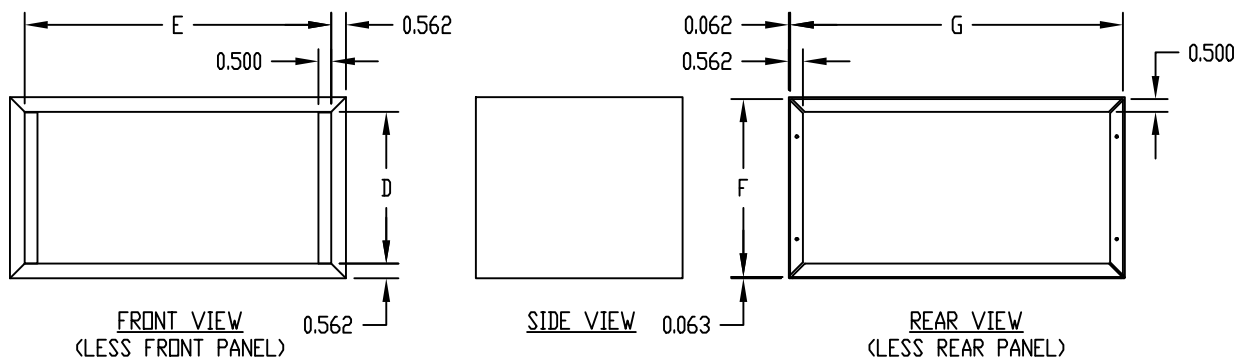
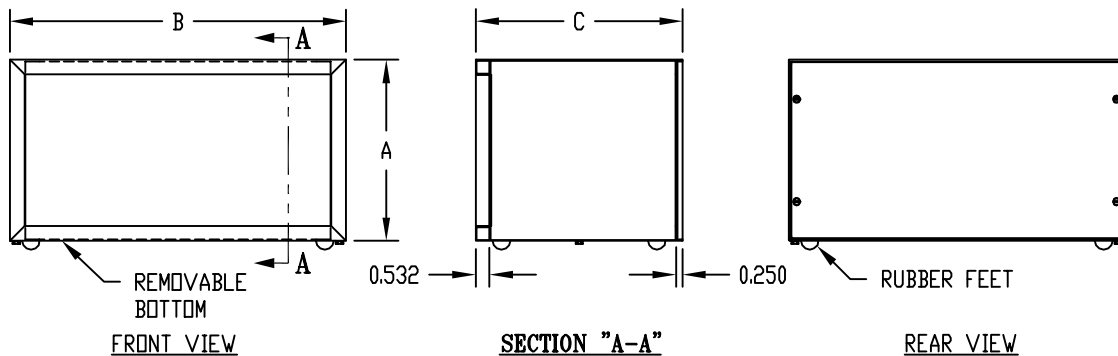

**FRONT PANEL**  
 (HOLES IN PANEL ARE FOR HANGING DURING THE FINISHING OPERATION)

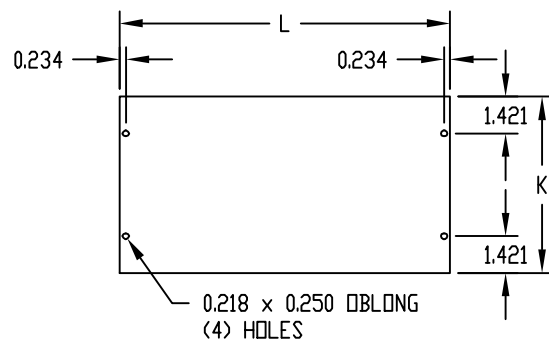

**REAR PANEL**

PART No.	OVERALL			PANEL SPACE				PANELS			
	A	B	C	FRONT		REAR		FRONT		REAR	
				D	E	F	G	H	J	K	L
MD-1960	7.000	13.000	8.000	5.875	11.875	6.875	12.875	6.890	11.812	6.812	12.781
MD-1961	8.000	14.000	9.000	6.875	12.875	7.875	13.875	7.890	12.812	7.812	13.781
MD-1962	8.000	16.000	9.000	6.875	14.875	7.875	15.875	7.890	14.812	7.812	15.781